

Impact Rankings 2024 Masterclass

Klara Spustek
Junior Impact Rankings
product owner

July 2024



Times Higher Education
Impact Rankings

Our Rankings

TEACHING

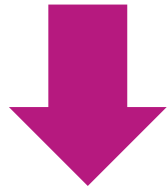

Focus: student satisfaction, employer reputation, graduation rate + more

Participation rules: ranking specific

RESEARCH

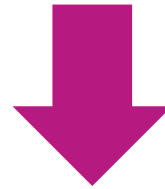

Focus: research output, research quality, research collaboration, reputation + more

Participation rules: 1,000+ publications over 5 years, teach undergraduates across a range of subjects

IMPACT & SUSTAINABILITY



Focus: research, teaching, stewardship and outreach against the UN's 17 Sustainable Development Goals

Participation rules: all UG or PG higher education institutions

What are the SDGs?



What do the SDGs mean, and what do they need?



- Sustainability
- Partnership
- Equity across the world
- Every community
- Sufficient resources
- Long term thinking



How does it work? (Outside in)



Times Higher Education
Impact Rankings

What are the Impact Rankings?

- 18 different rankings
- One for each SDG
- One overall ranking
- Data from Universities and from Elsevier



Ensure inclusive and equitable quality education and promote lifelong learning opportunities for all



Target	Description
4.1	By 2030, ensure that all girls and boys complete free, equitable and quality primary and secondary education leading to relevant and effective learning outcomes
4.2	By 2030, ensure that all girls and boys have access to quality early childhood development, care and pre-primary education so that they are ready for primary education
4.3	By 2030, ensure equal access for all women and men to affordable and quality technical, vocational and tertiary education , including university
4.4	By 2030, substantially increase the number of youth and adults who have relevant skills , including technical and vocational skills, for employment, decent jobs and entrepreneurship
4.5	By 2030, eliminate gender disparities in education and ensure equal access to all levels of education and vocational training for the vulnerable, including persons with disabilities, indigenous peoples and children in vulnerable situations
4.6	By 2030, ensure that all youth and a substantial proportion of adults, both men and women, achieve literacy and numeracy
4.7	By 2030, ensure that all learners acquire the knowledge and skills needed to promote sustainable development , including, among others, through education for sustainable development and sustainable lifestyles, human rights, gender equality, promotion of a culture of peace and non-violence, global citizenship and appreciation of cultural diversity and of culture's contribution to sustainable development
4.a	Build and upgrade education facilities that are child, disability and gender sensitive and provide safe, non-violent, inclusive and effective learning environments for all
4.b	By 2020, substantially expand globally the number of scholarships available to developing countries , in particular least developed countries, small island developing States and African countries, for enrolment in higher education, including vocational training and information and communications technology, technical, engineering and scientific programmes, in developed countries and other developing countries
4.c	By 2030, substantially increase the supply of qualified teachers , including through international cooperation for teacher training in developing countries, especially least developed countries and small island developing States

How do universities support the SDGs?



Calculating the annual score

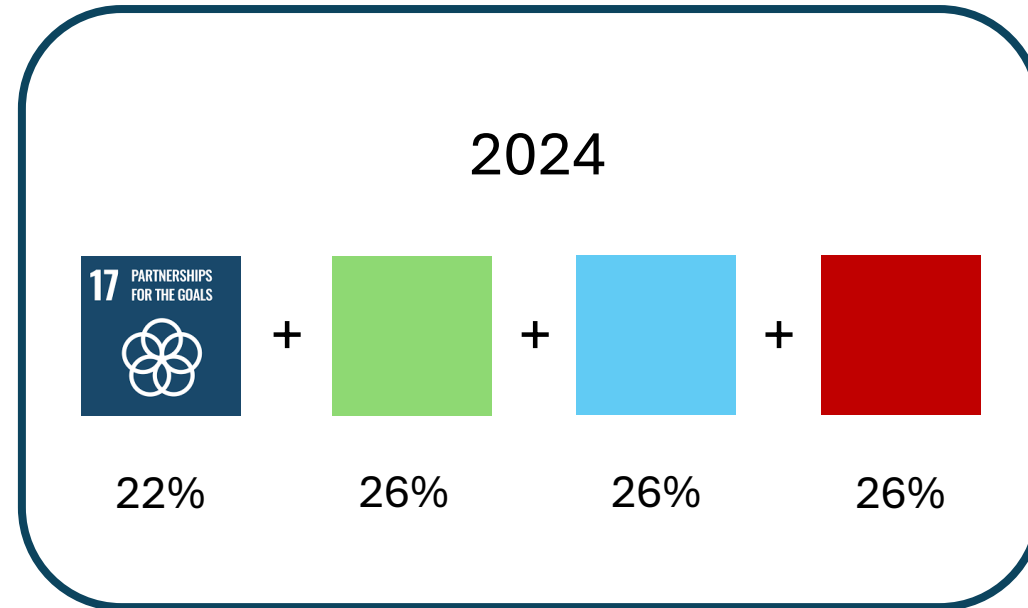

Overall score

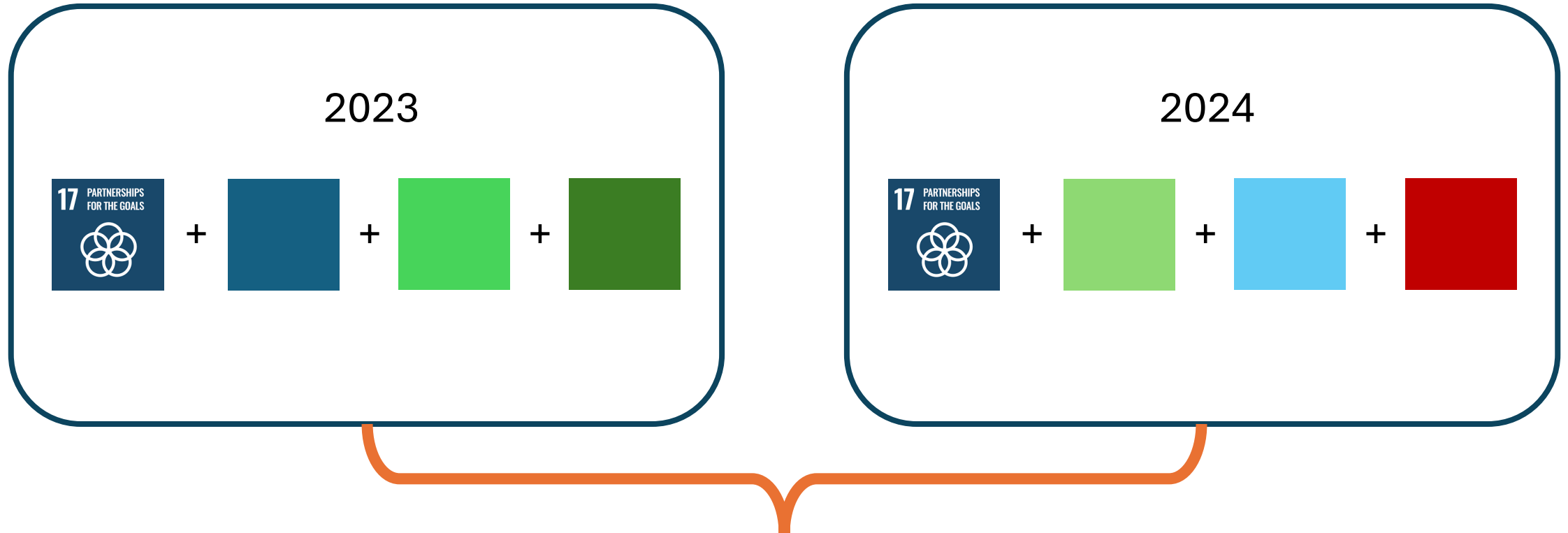

How does it work? (Inside out)



Times Higher Education
Impact Rankings

The Impact team



Chief Data Officer
Duncan Ross



Head of SDG
and Teaching Rankings
Hannah Peacock



Head of Data PMO
Emma Wilkin



MD of Data Science
David Watkins



Impact Jnr Ranking
Owner
Klara Spustek

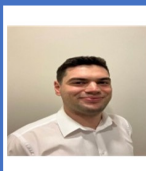

Senior Data Editor
Abdullah Arlsan



Supervisor
s 5



Onshore
Team
Up to 40



Offshore
Team
Up to 20



Data Scientist
Victor Melatti

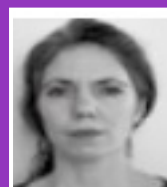

Senior Data
Scientist
Emma Deraze



Senior Data
Scientist
Mark Cadow



Impact cycle timeline



Impact 2024 High Level
Delivery Plan April, 2024

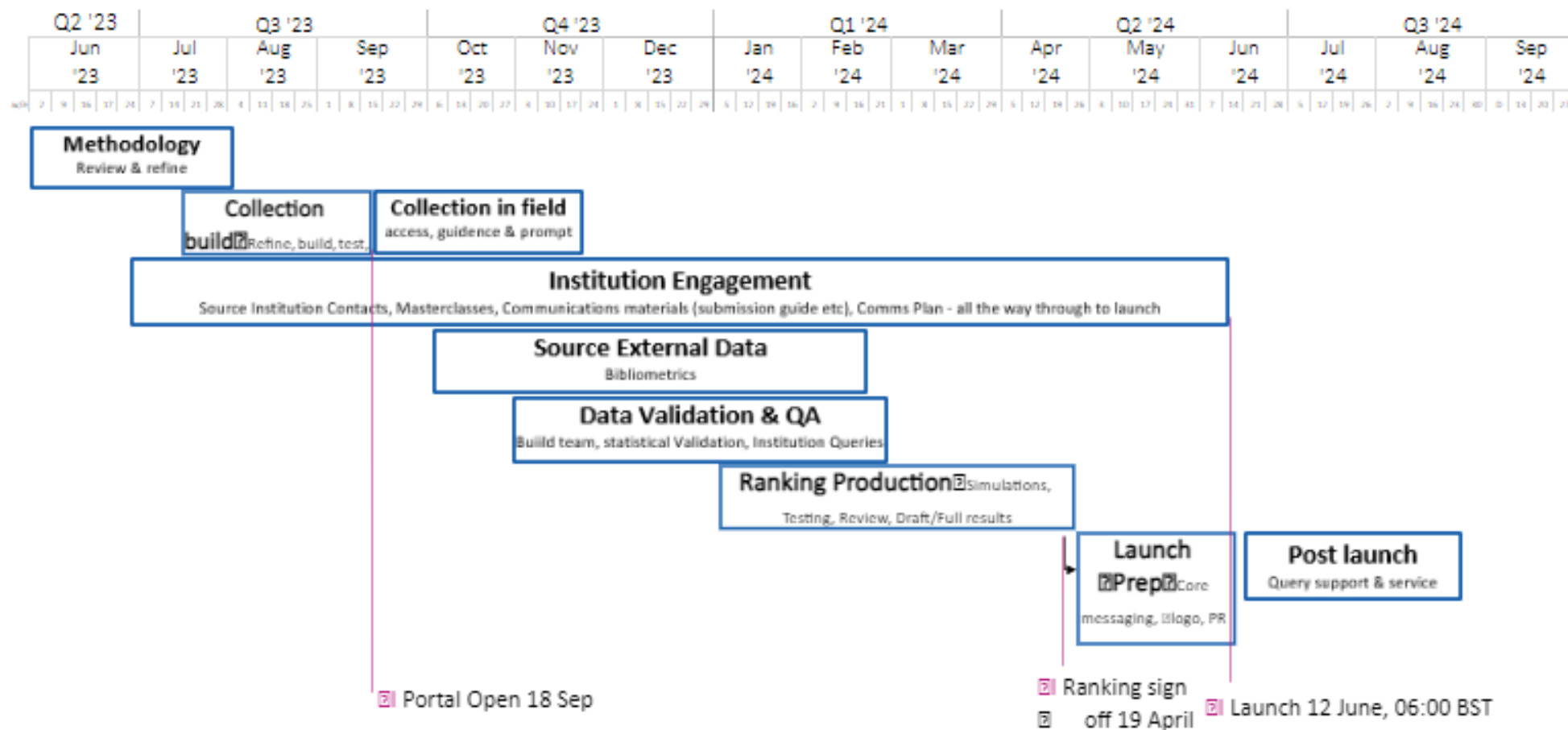

Data sources



Times Higher Education
Impact Rankings

Data for the ranking comes from two sources

University supplied data

- Numeric data
- Evidence data

Bibliometric data

- Provided by Elsevier

Evidence data

Some UN Targets don't lend themselves to strictly quantitative data

We need to be able to assess qualitative information too

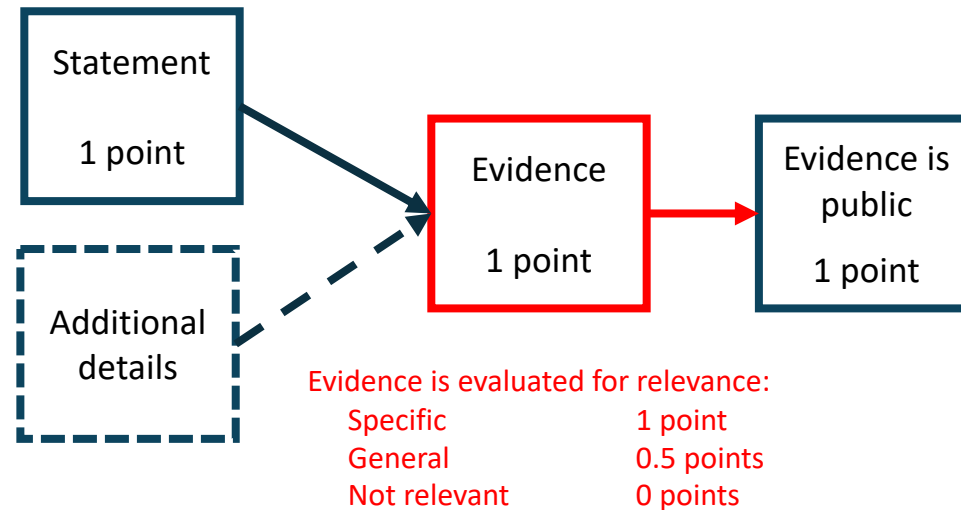

Evaluating the evidence data

This is not easy, documents are in multiple languages, websites change

Individuals are making decisions, but are supported by

- QA
- Comparison to previous years
- Rigorous training

This year

- Additional focus on consistency and QA of answers (helped by greater depth for comparison)



Overview of changes for 2025



Times Higher Education
Impact Rankings

Methodology changes

New question in SDG 17 looking at assessment of sustainable education.

Question will not be scored in 2025, but will allow us to understand progress:

- Are you assessing the level of sustainability literacy of your students?
- If yes, are you using Sulitest TASK or another system?
- What proportion of your student population is assessed?

Process changes

Only one piece of evidence will be used

- This will simplify assessment
- Some questions will be split into two as a result

We will use AI (Large Language Models) to support assessment

- Improvements to consistency
- Stronger feedback

Data collection dates : Opens on the 16th of September 2024 and closes on 11th of November 2024





Times Higher Education
Impact Rankings

The largest and most comprehensive global university ranking
dedicated to the UN sustainable development goals



2,152

Universities

30,000+

person hours (mainly evidence validation)

283,000+

documents collected

269,000+

measurements

3.7m

publications on the SDGs

75

metrics*

125

Countries and regions

251

indicators*



India result analysis



Times Higher Education
Impact Rankings

India in our rankings

In the following sections you will see details about participation and performance of your selected country in three Times Higher Education rankings: World University Rankings (WUR), Impact Rankings and Reputation Rankings.

WUR (RANKED)	WUR (PARTICIPANTS)	IMPACT (OVERALL RANKING)	IMPACT (ANY SDG)	REPUTATION (TOP 200)	REPUTATION (TOP 1000)
91	111	96	105	4	38

Universities in all rankings

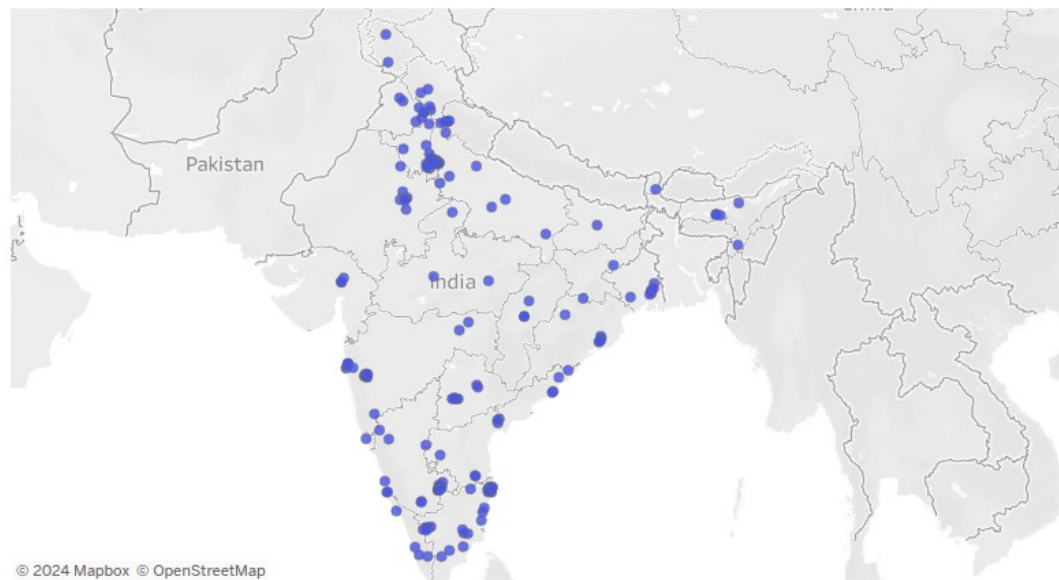

Ranked universities over time (by year of publication)

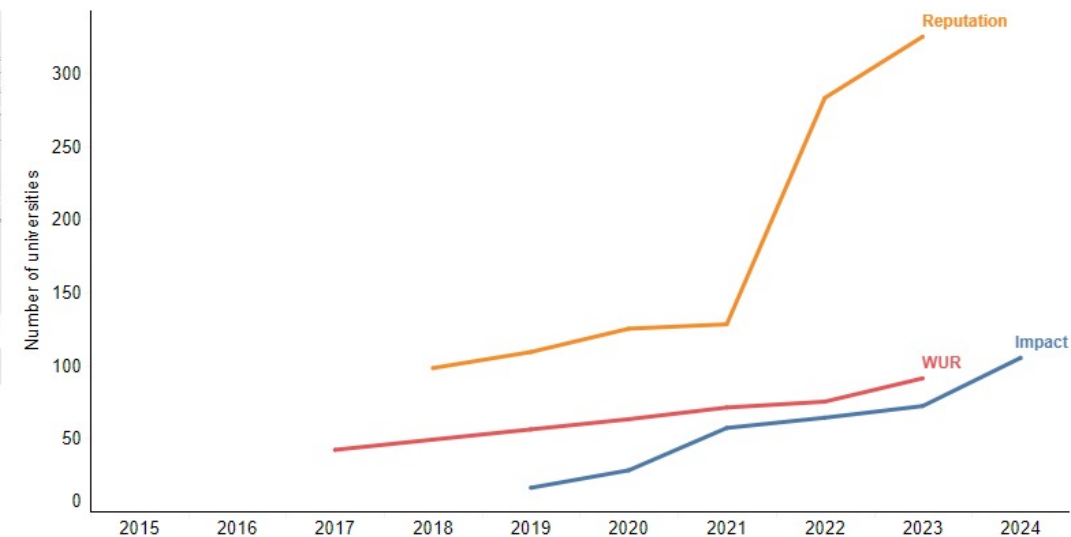

Impact rankings 2024: India

Our Impact Rankings are the only global performance tables that assess universities against the United Nations' Sustainable Development Goals (SDGs).

We use carefully calibrated indicators to provide comprehensive and balanced comparisons across four broad areas: research, stewardship, outreach and teaching. Those ranked are comprised one one ranking for each of the 17 UN SDGs, and an Overall ranking which assesses universities across their 3 best SDGs + SDG17.

Click on the button on the top right to find more about our Impact Rankings methodology.

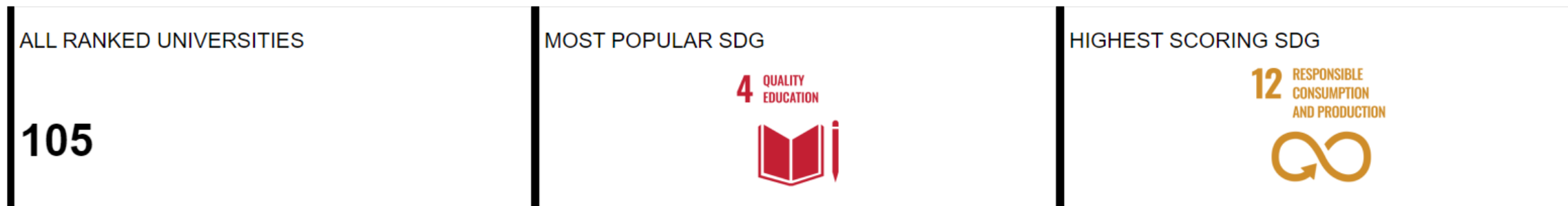

Highest ranked universities Overall

Amrita Vishwa Vidyapeetham	ranked =81
Shoolini University of Biotechnology and Management Sciences	ranked 101–200
Lovely Professional University	ranked 101–200
Manipal Academy of Higher Education	ranked 101–200
JSS Academy of Higher Education and Research	ranked 101–200



Most participated SDGs

3 

GOOD HEALTH AND WELLBEING

SCORE RANK
75.0 **201-300** out of 1498 institutions

[Details](#)

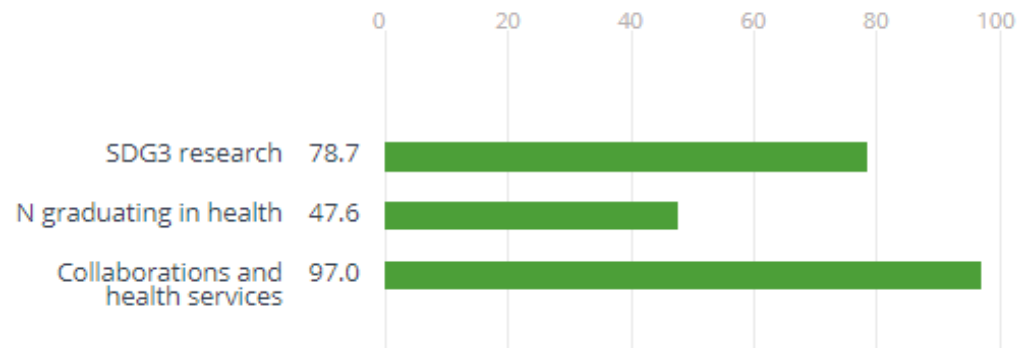

4 

QUALITY EDUCATION

QUALIFYING SDG - 26% OF OVERALL

SCORE RANK
91.4 **1** out of 1681 institutions

[Details](#)

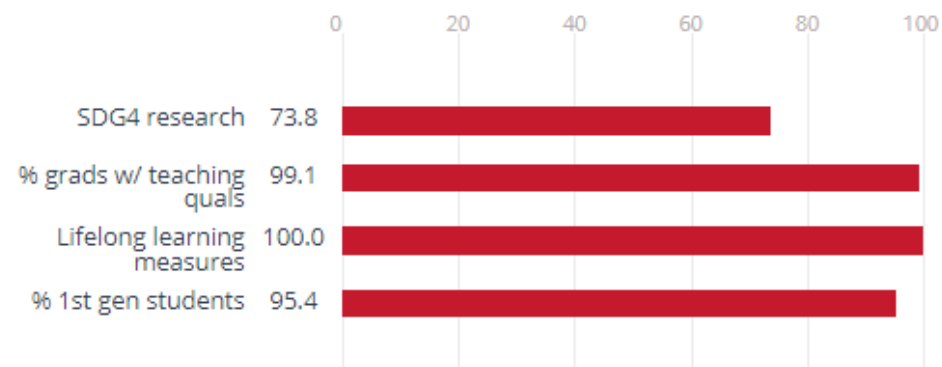

SDG 7: Affordable and Clean Energy



Times Higher Education
Impact Rankings

Themes



7

AFFORDABLE AND CLEAN ENERGY

QUALIFYING SDG - 26% OF OVERALL

SCORE **64.5** RANK **95** out of **560** institutions

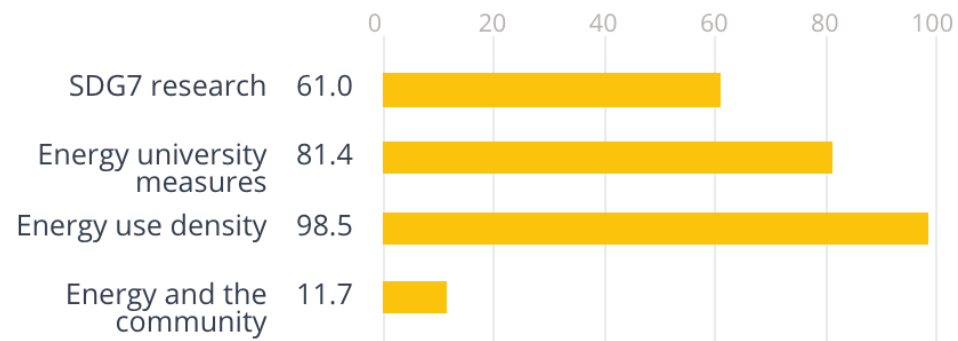

Top 10



Rank	2023	Name	Country
1	10	Afe Babalola University	Nigeria
2	2	National Autonomous University of Mexico	Mexico
3	18	Saveetha Institute of Medical and Technical Sciences	India
4	13	University of Malaya	Malaysia
5	43	Shoolini University of Biotechnology and Management Sciences	India
=6	601–800	National University of Modern Languages (NUML)	Pakistan
=6	101–200	Arab Academy for Science, Technology and Maritime Transport	Egypt
8	-	SRUC (Scotland's Rural College)	United Kingdom
9	9	King Faisal University	Saudi Arabia
10	401–600	Benha University	Egypt



Research on Energy



SDG Impact Dashboard

Powerful data and analytics to support success in sustainability

India

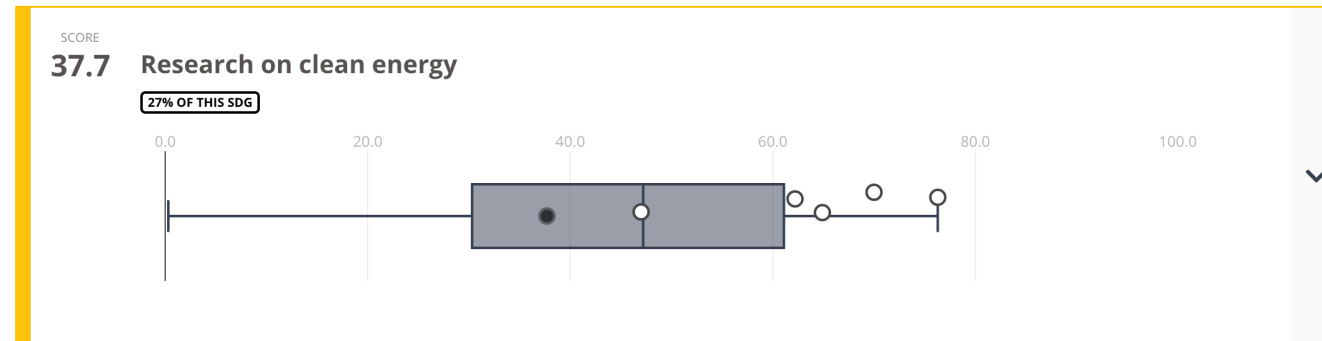

Asia

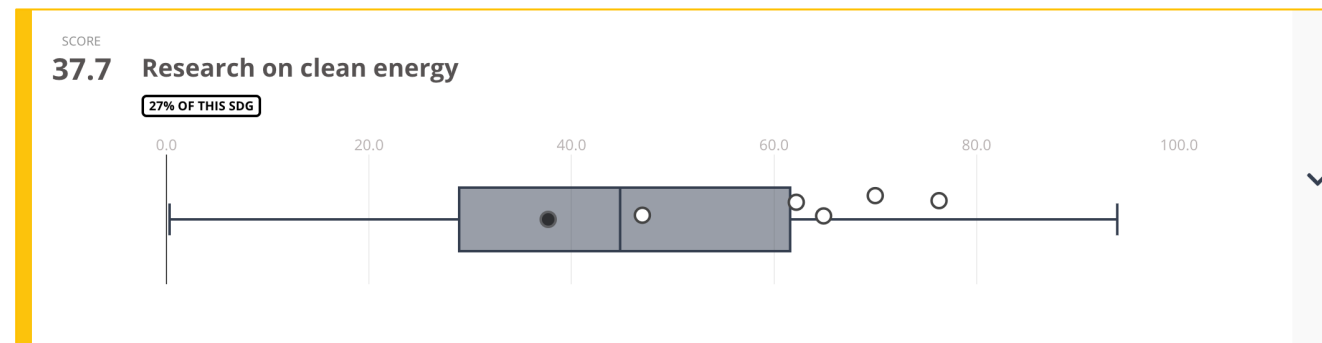

Europe

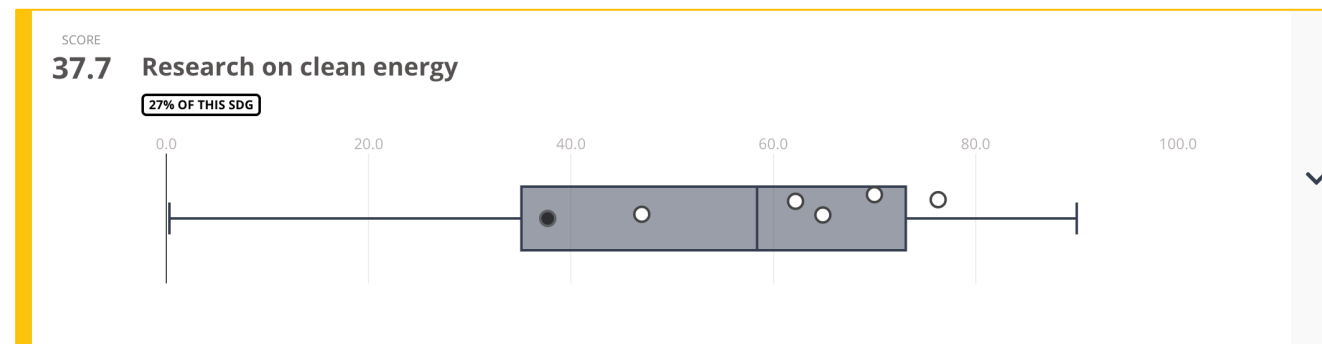

Energy use density



SDG Impact Dashboard

Powerful data and analytics to support success in sustainability

India

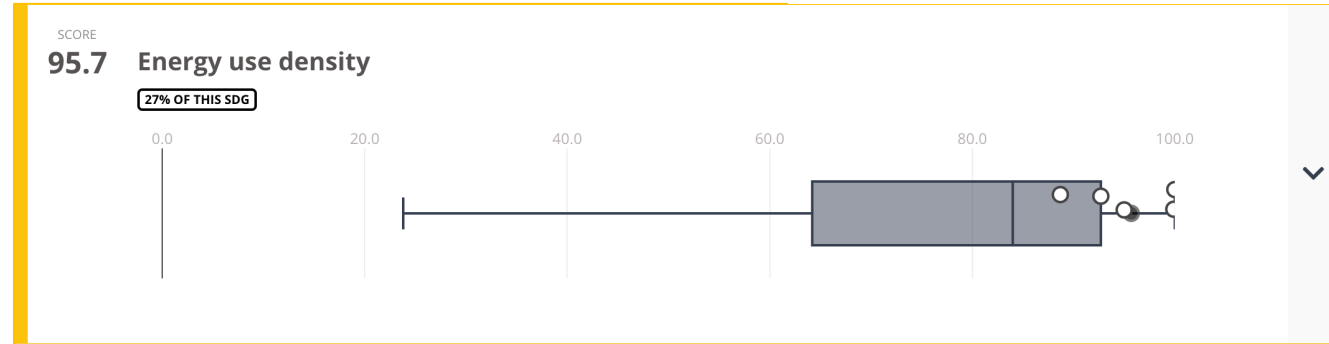

Asia

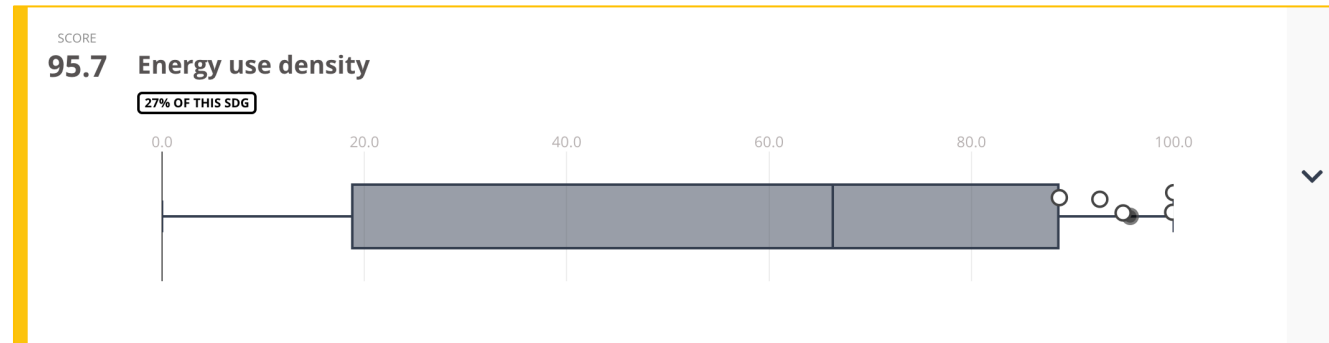

Europe

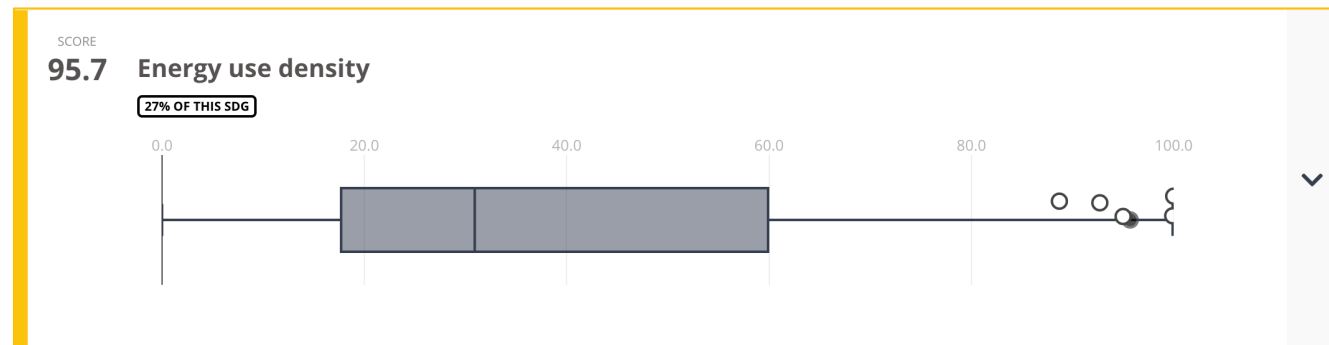

SDG 3 Good health and well-being



Times Higher Education
Impact Rankings

SDG 3 Good health and well-being: top 10 universities

Why we measure

Ensuring healthy lives and promoting well-being at all ages is essential to sustainable development. There is an urgent need to fully eradicate a wide range of diseases and address many different persistent and emerging health issues. We are exploring how universities deal with specific conditions and diseases, and support their community.

<https://www.un.org/sustainabledevelopment/health>

JSS Academy of Higher Education and Res	India	1
Australian Catholic University	Australia	2
Mahidol University	Thailand	3
Fujita Health University	Japan	4
RCSI University of Medicine and Health Sc	Ireland	5
Kaohsiung Medical University	Taiwan	6
Amrita Vishwa Vidyapeetham	India	7
National Taiwan University (NTU)	Taiwan	8
University of Tasmania	Australia	9
James Cook University	Australia	=10
Lithuanian University of Health Sciences	Lithuania	=10



SDG 3 Best practice

JSS Academy Of Higher Education & Research,
India

Access to
mental health support

About Us

Student Support Center (SSC) is formed at JSS AHER, Mysuru with the support of the Department of Psychiatry and the Department of Clinical Psychology.

Student Support Center (SSC) provides free and confidential direct individual counseling services for a variety of concerns including, stress, burnout, time management, relationship problems, anxiety, depression, and other matters related to a student's overall mental well-being. The Center also provides resource information on wellness topics and is responsible for student outreach programming designed to reduce stress and improve overall well-being.



Aim



Aims to provide comprehensive services under one roof to the students/staff. JSS AHER is a university that is constantly striving to maintain international standards of excellence, certainly in academic output, but equally in the holistic emotional, mental, and physical well-being of its students/staff. The World Health Organization has identified depression as the single largest contributor and the leading cause of mental and physical disability across the world. It is the second leading cause of death (by suicide) in the 15 - 29 years age group. According to the National Crime Records Bureau, a suicide is committed in India every five minutes and a third of all suicides in India fall within this age group. The Student Support Centre has linked with the WHO campaign on raising awareness around mental health and aspires to contribute to public education about issues that affect young people, such as sexual abuse, suicide, and substance abuse. etc.

SDG 4 Quality Education



Times Higher Education
Impact Rankings

SDG 4 Quality Education: top 10 universities

Why we measure

A high-quality education should be an area where universities excel. Education is a key gateway out of inequalities, especially multigenerational ones. In addition to improving quality of life, access to inclusive education can help equip locals with the tools required to develop innovative solutions to the world's greatest problems. SDG 4 explores early years and lifelong learning. We are exploring how universities support early years, lifelong learning, and their nations through ensuring equality of access to their facilities. Although the UN includes Education for Sustainable Development in SDG 4, we have chosen instead to measure that as part of SDG 17, as this is the mandatory SDG within our ranking, and in the case of Universities it is a key factor of partnership around the goals.

<https://www.un.org/sustainabledevelopment/education/>

Aalborg University	Denmark	1
Hong Kong Baptist University	Hong Kong	2
Amrita Vishwa Vidyapeetham	India	3
The Hong Kong Polytechnic University	Hong Kong	4
Istanbul Technical University	Turkey	5
National and Kapodistrian University of Athens	Greece	6
Allama Iqbal Open University	Pakistan	7
Khwaja Fareed University of Engineering and Information Technology	Pakistan	8
Abdullah Gül University	Turkey	9
Ahlia University	Bahrain	10



SDG 4 Best practice

Aalborg University, Denmark

Public access to educational resources

WE ARE A

PUBLIC LIBRARY

Aalborg University Library is a public library with free access. Our main task is to service and support Aalborg University. However, any permanent resident may obtain a free library card and use our print collections and library facilities during regular opening hours at no charge. The library computers also provide free access to our online resources.

- Create a profile (library registration form)
- Branches and opening hours



Good news and bad news

We might as well tell you right away, private individuals with no current affiliation to Aalborg University *cannot* use our electronic resources from home! But you *can* access the resources, if you come to one of our branches during regular opening hours.

SDG 12 Responsible Consumption and production



Times Higher Education
Impact Rankings

SDG 12: top 10 universities

Why we measure

Much of the world's economy is based around producing things for consumption. This drives the engine of industry. If we want the world to develop sustainably, we need to understand how to be more responsible at both ends of this cycle. This means promoting resource and energy efficiency, having a sustainable infrastructure, and providing access to basic services for all. We are exploring how universities are working towards an efficient use of resources and the minimization of waste.

<https://www.un.org/sustainabledevelopment/sustainableconsumption-production/>

Bournemouth University	United Kingdom	=1
King's College London	United Kingdom	=1
University of Reading	United Kingdom	3
Western Sydney University	Australia	4
University of Sheffield	United Kingdom	5
University of Plymouth	United Kingdom	6
University of Exeter	United Kingdom	=7
University of Manchester	United Kingdom	=7
Swansea University	United Kingdom	9
University of Canterbury	New Zealand	=10
University of Galway	Ireland	=10



SDG 12 Best practice

Bournemouth University,
United Kingdom

Does your university as a body have a policy
on ethical sourcing of food and supplies?



Title:	Sustainable and Ethical Food Policy
Keywords:	Food, Sustainable, Catering, Tourism, Fairtrade, Environment, Procurement
Description:	A policy detailing the responsibilities for managing the sustainability of food provision and disposal at all BU catering provisions
Owner:	Sustainability Committee
Version number:	11
Date of approval:	1 November 2010
Approved by:	Sustainability Committee
Effective date:	2 November 2010
Date of last review:	April 2023
Due for review:	April 2024
Audience:	Staff, Students & Suppliers

Sustainable and Ethical Food Policy

1. SCOPE AND PURPOSE

- 1.2 This policy applies to all catering facilities within the Bournemouth University (BU) estate operated by its partners, Chartwells and the Students' Union.
- 1.3 The Policy forms part of BU's Environmental and Energy Management System, which is certified to EcoCampus Platinum and ISO14001 and ISO50001.
- 1.4 BU's implementation of this Policy contributes to achieving the UN Sustainable Development Goals.

2. KEY RESPONSIBILITIES

- 2.1 It is the responsibility of the managers of catering facilities within BU to ensure their services adhere to this policy.
- 2.2 The BU Sustainability Committee is responsible for overseeing the implementation and monitoring of this policy.

3. LINKS TO OTHER BU DOCUMENTS

- 3.1 Bournemouth University Sustainability Policy
- 3.2 Bournemouth University Sustainable Procurement Policy
- 3.3 Bournemouth University Fairtrade Policy
- 3.4 Bournemouth University Climate & Ecological Crisis Action Plan (CECAP)

Additional Support

FAQ page

Impact@TimesHigherEducation.com



Access THE's sustainability dataset via:



DataPoints

SDG Impact Dashboard

Powerful data and analytics to support success in sustainability.

Request a free demo: data@timeshighereducation.com

